



OPTIMAST

OPTIMAST
HOT
DROPS
from page 48

www.optimast.pl

© Marek Komorowski

CATALOGUE

FOR

Thank You for trust and feedback, Sailors!

First of all we would like to thank you, Dear Sailors for all your support, feedback and love You are giving us.

Without You we wouldn't be able to perform such a great results in such short period of time. Your commitment, guidance, patience and understanding made us more confident than ever.

We want to create, we want to evolve, we want you to sail faster and feel a lot of joy, because that's what sailing is all about.

All our products are made with passion and dedication for You.

#KeepOnSailing!



—
European Champion 2018
European Vice-Champion 2017
—

About us

Optimast is a brand that has been in the sailing industry for over 8 years. We are introducing and developing new technologies in the Optimist dinghy for you to achieve better and better results. We listen to your feedback to make our products even better. We are proud to announce that our products are delivered to 48 countries worldwide and are used by best sailors in European and World Championships every year.

Optimast frequently introduces new technological improvements. After a very durable porcelain anodizing process, we introduced the new PRO L.E. boom made of G.R.T. aluminum, which created new possibilities for kit adjustment. Its lightness and stiffness allows for a more accurate adjustment of the sail depending on the conditions on the water, thanks to which it has become the most versatile boom on the market and can be used in a variety of Optimast kit configurations to suit your personal taste.

2021 is the time for the Super Flex Gold, which is used by top riders due to its compatibility with many sails from different manufacturers.

The Optimast team is not standing still and is already working with sailors from around the world. The Optimast team is not standing still and is already working with sailors around the world to make new and even better improvements to make sailing as efficient and fun as possible.

Our products are fully compatible with IODA conditions.

All products have 24 month warranty and free service during big regatta events



**Spars
and equipment**



BLACK SPAR SET

Best for 40+kg sailors

NEW
PRODUCT!

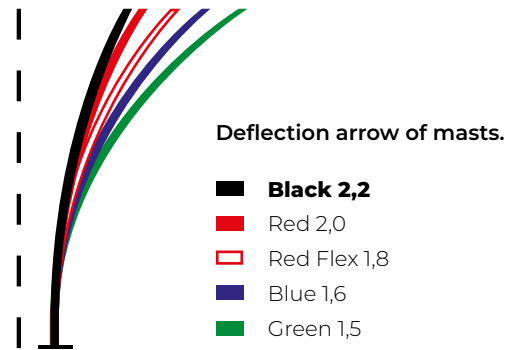

About

This **NEW** spar set is the stiffest one produced by Optimast. It's dedicated to heavier sailors, who have very good skills in navigating the boat in strong winds. The material used to make the Black Optimast set is modified by us aluminium G.R.T. Alloy.

Hard anode

Black set contains:

- Ultimate racing mast # 2,2 mm / G.R.T. Alloy - **WZ-4100**
- Ultimate racing boom \varnothing 45 mm # 1,2 mm / G.R.T. Alloy - **WZ-8000**
- Ultimate racing sprit \varnothing 28 mm # 1,2 mm / AW 7095 - **WZ-4300**
- LESS STIFFER OPTION:**
- Ultimate racing sprit \varnothing 28 mm # 1,2 mm RED / AW 7075 - **WZ 3300**
- Ultimate racing sprit \varnothing 26 mm # 1,2 mm M.G. Option / AW 7020 - **WZ-6000**

*Accessory starter package included - **A-250**

BLACK mast weight: 1920g

Catalogue No.
WZ - 4000



RED SPAR SET

Best for 35+kg sailors

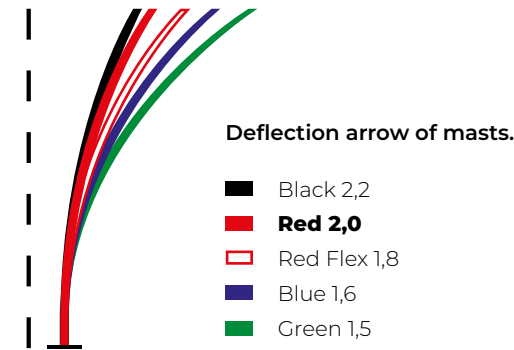

About

This spar set was derived from experiments and tests. It is more resilient than the material used in Black Optimast, with wall thickness of 2.0 mm, which gave this set more dynamic character, forgiving passive conducting of the boat and enabling sail opening in case of strong wind gusts. Extra boom choice gives you an option to personalise the set for your needs.

Hard anode

Red set contains:

- Ultimate racing mast # 2,0 mm / AW 7075 - **WZ 3100**
- Ultimate racing boom \varnothing 45 mm # 1,2 mm / G.R.T. Alloy - **WZ-8000**
- Ultimate racing sprit \varnothing 28 mm # 1,2 mm / AW 7075 - **WZ 3300**
- LESS STIFFER OPTION:**
- Ultimate racing sprit \varnothing 26 mm # 1,2 mm M.G. Option / AW 7020 - **WZ-6000**
- Ultimate racing sprit \varnothing 26 mm # 1,2 mm / AW 7075 SUPER FLEX GOLD - **WZ-7000**

*Accessory starter package included - **A-250**

RED mast weight: 1790g

Catalogue No.
WZ - 3000





RED FLEX SPAR SET

Best for 30+kg sailors

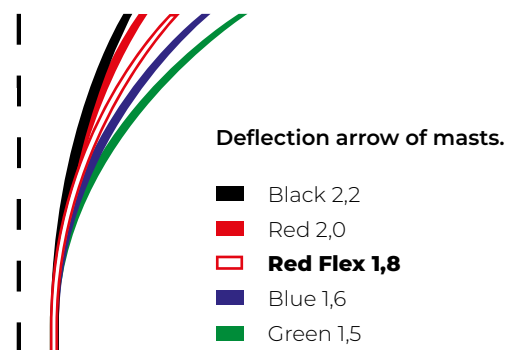

About

Red Flex is an important link between all of our sailing sets. We noticed that most of the coaches select sets of sprits with a larger arrow of deflection and lower weight. On the basis of experience, a set of Red Flex fills the gap between Blue and Red spar set. Red Flex spar set is especially good when sailing on the open waters with more waves. This set is very dynamic. There is no equivalent spar produced in the world.

Hard anode

Red Flex set contains:

Ultimate racing mast # 1,8 mm / AW 7025 - **WZ 5100**

Ultimate racing boom ø 40 mm # 1,5 mm / AW 7075 - **WZ 5200**

Ultimate racing sprit ø 26 mm # 1,2 mm / AW 7095 - **WZ 5300**

OPTIONAL:

Ultimate racing boom ø 45 mm # 1,2 mm / G.R.T. Alloy / PRO L. E. - **WZ-8000**

Ultimate racing sprit ø 26 mm # 1,2 mm M.G. Option / AW 7020 - **WZ-6000**

Ultimate racing sprit ø 26 mm # 1,2 mm / AW 7075 SUPER FLEX GOLD - **WZ-7000**

*Accessory starter package included - **A-250**

RED FLEX mast weight: 1620g

Catalogue No.
WZ - 5000



BLUE SPAR SET

Best for 25+kg sailors

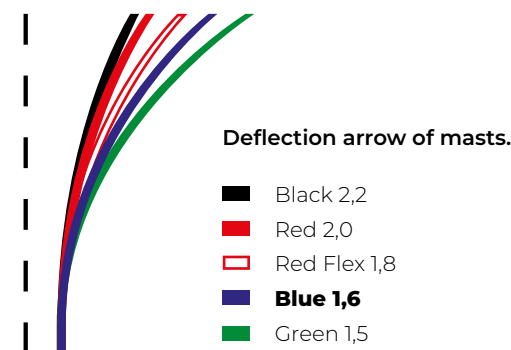

About

It is a still unknown design of the AW 7020 thin-walled tube. Its high elasticity perfectly conveys the dynamics of the sail onto the hull, under the conditions of light wind. However when the wind picks up, light weight sailors can keep the boat flat much easier. This spar set is especially good when the waves are irregular.

Hard anode

Blue set contains:

Ultimate racing mast # 1,6 mm / AW 7020 - **WZ-2100**

Ultimate racing boom ø 40 mm # 1,5 mm / AW 7075 - **WZ-2200**

Ultimate racing sprit ø 26 mm # 1,2 mm / AW 7075 SUPER FLEX GOLD - **WZ-7000**

OPTIONAL:

Ultimate racing boom ø 45 mm # 1,2 mm / G.R.T. Alloy / PRO L. E. - **WZ-8000**

*Accessory starter package included - **A-250**

BLUE mast weight: 1410g

Catalogue No.
WZ - 2000





GREEN SPAR SET

NEW PRODUCT!

Best for 20< sailors

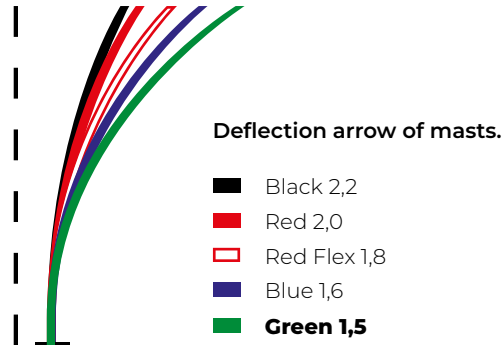

About

We decreased its inner thickness, making the Green mast even more light and flexible, thanks to the new stiffer and more durable material AW 7020. It keeps its previous role, being a great choice for novice and very light sailors, however its new parameters make the Green mast even better in competitive sailing. This mast is the lightest mast on the market at the moment.

Hard anode

Green set contains:

Ultimate racing mast # 1,5 mm / AW 7020 - **WZ 1100**

Ultimate racing boom ø 40 mm # 1,1 mm / AW 7005 (SUPER LIGHT) - **WZ 1200**

Ultimate racing sprit ø 28 mm # 1,4 mm / AW 6082 - **WZ 1300**

*Accessory starter package included - **A-250**

GREEN mast weight: **1380 grams**



Mast and boom is fully equipped with ropes.

Starter package A-250

included for every spar set



WZ - 022 A

Halyard with Friction Ring 5x7



WZ - 032

Optimast claw block



WZ - 014

Mast slip band Teflon HD



A - 160

Halyard line PSE / Kv 1350 mm



A - 171

Optimast handle



WZ - 018

Wind Indicator top pins



WZ - 017 B

Optimast Epoxy wind indicator



A - 100

Regatta lacing lines

*Rest of the ropes attached directly to the spars

New material **Double-bounded**



Optimast ClawBlock **Improved in 2022!**

New material **Reinforced for more durability**

Withstands **300kg load!**



Catalogue No. **WZ - 032**

2020

EUROPEAN CHAMPION EDITION



special **GOLD** edition - most flexible sprit made with super light and durable materials.

Good option for every spar set!



Catalogue No.
WZ - 7000

2019

RED FLEX OPTION

World Championship
winner in **2019**

Catalogue No.
WZ - 7000



SUPER FLEX GOLD

Catalogue No.
WZ - 7000



**Fully customizable
Optimist spar sets.**
To suit Your needs.



UPDATED
PRODUCT



PRO
LIMITED
EDITION

Our double layer anodization process gives
top quality look and durability



Catalogue No.
WZ - 8000

G.R.T. ALLOY #1.2 mm

Our monel nites gives
water sealing assurance



We push Optimist sailing
further with ideas

Crafted
with
care
and
passion
to every detail

Mast
Equipment

OPTIMUM MAST



WZ - 009 A
ClamCleet
CL-211 MK.2/S2
Black



WZ - 009 B
ClamCleet
CL-211 MK.2/S2
Black



WZ - 010
Mast pin



WZ - 011 A/B
High mast
heel plug
A: #2.2 mm
B: #2.0 mm



WZ - 012 A/B/C
Low mast
heel plug
A: #1.8 mm
B: #1.6 mm
C: #1.5 mm



WZ - 013 A
Mast sticker



WZ - 014
Mast slip band
Teflon HD



WZ - 017 A
Wind indicator
Epoxy Black



WZ - 017 B/C/D
Wind indicator
B: Set
C: Strut only
D: Indicator only



WZ - 018
Wind indicator
top pins
Set



A - 100
Regatta lacing
lines

A - 250 A



Set includes:

- WZ - 022 B** Halyard line with Friction Ring 4x8
- WZ - 032** Optimast Claw Block
- A - 160** Halyard line PSE / Kv 1350 mm
- A - 171** Optimast Handle

A - 250 B



Set includes:

- WZ - 022 A** Halyard line with Friction Ring 5x7
- WZ - 032** Optimast Claw Block
- A - 160** Halyard line PSE / Kv 1350 mm
- A - 171** Optimast Handle

A - 250 C



Set includes:

- WZ - 022** Halyard line with Friction Ring 7x10
- WZ - 032** Optimast Claw Block
- A - 160** Halyard line PSE / Kv 1350 mm
- A - 171** Optimast Handle



WZ - 007

Polyurethane glue for plastic fittings



WZ - 008

polyolefin shrink wrap
Ø30 mm
140 mm long



WZ - 021 A/B

Sprit ends
A: Ø26 mm
B: Ø28 mm

Mast Equipment

Boom Equipment

Sprit Equipment



WZ - 001

Span with safety snap shackle
Mini Speedy
220 mm



WZ - 002

Ronstan snap shackle
Mini Speedy
34 mm



WZ - 004 A

Boom measure sticker



WZ - 004 B

Clew position indicating sticker



WZ - 005

Outhall
Dyneema line
Armare Tapered
Ø2 mm < Ø5,5 mm



WZ - 006

Boom groomet with nites



WZ - 015 A/B

Boom outboard end
A: Ø40 mm
B: Ø45 mm



WZ - 016 A/B

Boom inboard end
A: Ø40 mm
B: Ø45 mm



WZ - 019

Stainless steel rings for boom
Ø15 mm #2,5 mm



WZ - 020

Boom bridle
1650 mm
DynaOne
Ø3 mm
2x Stainless Steel Rings



A - 140

DynaOne Boom Vang for splicing



A - 168

Holt Boom Cleat

OPTIMAST

Spar Blocks



WZ - 023

Sprit halyard rope with Ronstan block 25109
 Ø20 mm
 DynaOne 670 mm



WZ - 024

Sprit halyard rope Nautos 2020 T
 Ø 20 mm
 DynaOne 670 mm



WZ - 025

Sprit halyard rope Nautos block N 2020 Dynamic
 Ø 20 mm
 DynaOne 670 mm



WZ - 022

Halyard line with spliced lowfriction ring
 4x8
 600 mm long



WZ - 022 A

Halyard line with spliced lowfriction ring
 5x7
 600 mm long



WZ - 022 B

Halyard line with spliced lowfriction ring
 7x10
 600 mm long



WZ - 022 C

Clawblock with Halyard line and lowfriction ring
 4x8
 600 mm long



WZ - 022 D

Clawblock with Halyard line and lowfriction ring
 5x7
 600 mm long



WZ - 022 E

Clawblock with Halyard line and lowfriction ring
 7x10
 600 mm long



WN - 026 A

S halyard rope block with line
 Ø20 mm



AN - 122N

Long lasting tapered Armare four component line Ø5,6 mm
 530 mm long



WZ - 026

Ronstan 25109
 Ø 20 mm



WZ - 027 A

Nautos HT2020 T without hanger
 Ø 20 mm



WZ - 027 B

Nautos HT2020 T with hanger
 Ø 20 mm



WZ - 028

Nautos 2020 Dynamic
 Ø 20 mm



WZ - 030

Ronstan 55 Ratched Block RT Orbit super light



WZ - 031

Nautos 57 Ratched Block



NEW PRODUCT!

WZ - 032

Optimast CLAW BLOCK



WZ - 033

Ronstan 45111
 Ø 40 mm



WZ - 034

Ronstan 45111
 Ø 40 mm
 Set with Ronstan 2454 holder



WZ - 036

Nautos Block HT2040 T
 Ø 40 mm



WZ - 036 B

Nautos Block HT2040 T
 Ø 40 mm with hanger



WZ - 037

Nautos Block HT2040 T
 Ø 40 mm
 Set with Ronstan 2454 holder



WZ - 039

Nautos Block HT2030T
 Ø30 mm



WN - 040

S Halyard rope block
 Ø20 mm

OPTIMAST

OPTIMAST wind indicator

—
UPGRADED

Two of our designs
to guide you the right way



Catalogue No.
WZ - 017 A



NEW SECURITY SYSTEM

Catalogue No.
WZ-N-017 B



A - 191

Maffioli Regatta Vectran mainsheet with loop
8 mm / 7,2 m



AN - 234

Armare tapered non-symmetrical Mainsheet
GAMBERUS 2.0
7,95 m



AN - 235

Armare tapered non-symmetrical Mainsheet
GAMBERUS Plus 2.0
7,95 m



A - 194

Elana regatta Mainsheet
8 mm / 8 m
ELA/ Pps



AN - 195

Self-clamping loop for 3/4 mainsheet system

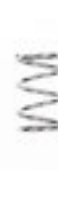

WZ - 040

Optimast 28 mm spring
L - 45 mm



WZ - 043 A

Small Ronstan holder 2454



WZ - 043 B

Large Ronstan holder 2454

Mainsheets

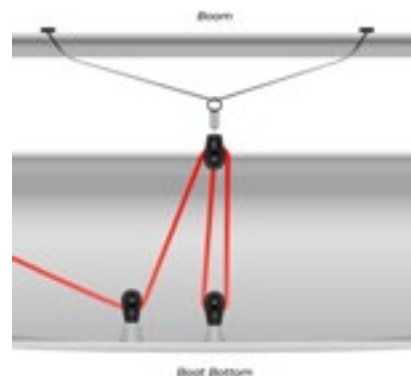
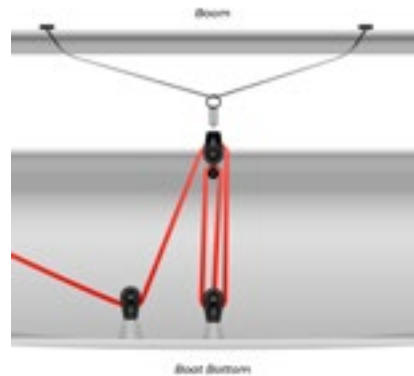

OPTIMAST SUGGESTED SETUPS

LOW FRICTION RINGS DIAMETERS

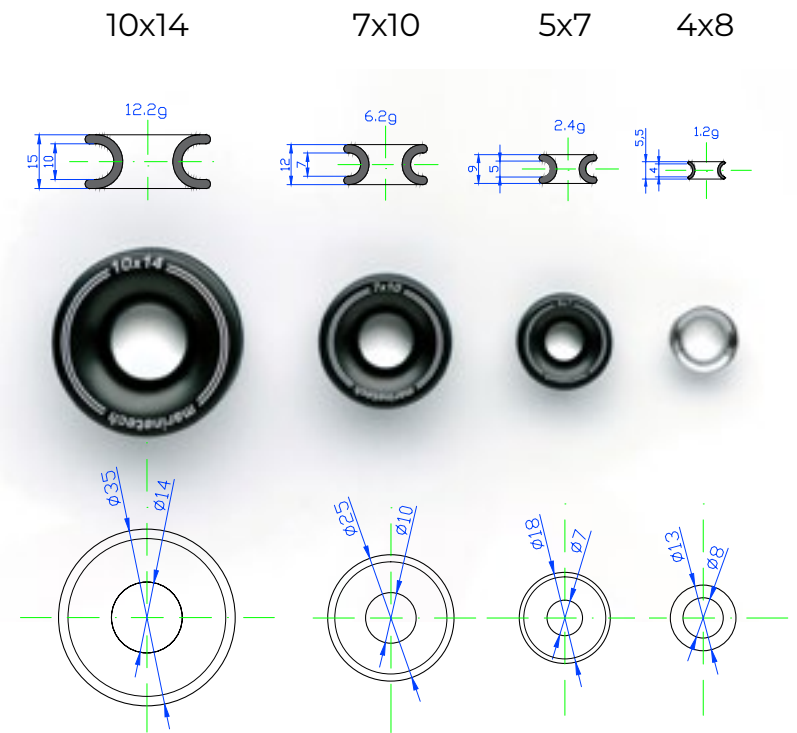

NEW!

LASER TAGING

The latest technology to upgrade our products



**Trolleys
and equipment**

OPTIMAST IMPROVED TROLLEY

OP-5 INNOVATION



**BEST
SELLER**

Best selling trolley
sold in two sizes!

A - 1120 mm

B - 1200 mm

New side support
made with soft material

LIGHT, DURABLE, UNRIVALLED.

Our best designed trolley combines premium durability, light materials, innovative design and assembly easiness. Ready to go in 3 simple steps. Extreme light construction that weights only 4 kilograms with slip rollers for easier launching and pulling dinghy out of the water. Double fine designed locking system allows you to store dinghy in two positions - normal position for transport and upside down position to clean and dry your equipment.

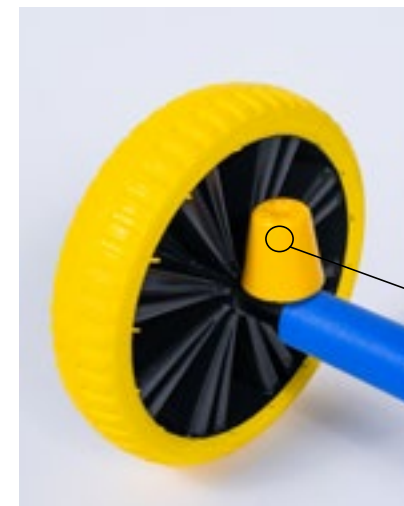
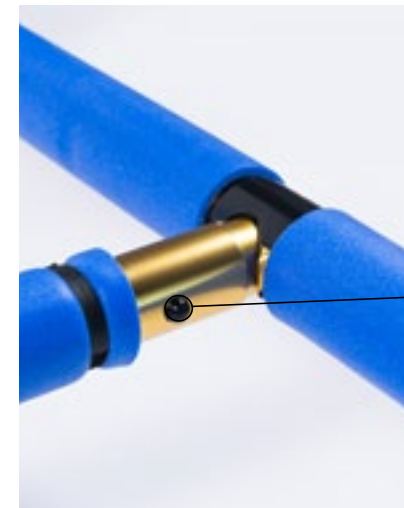
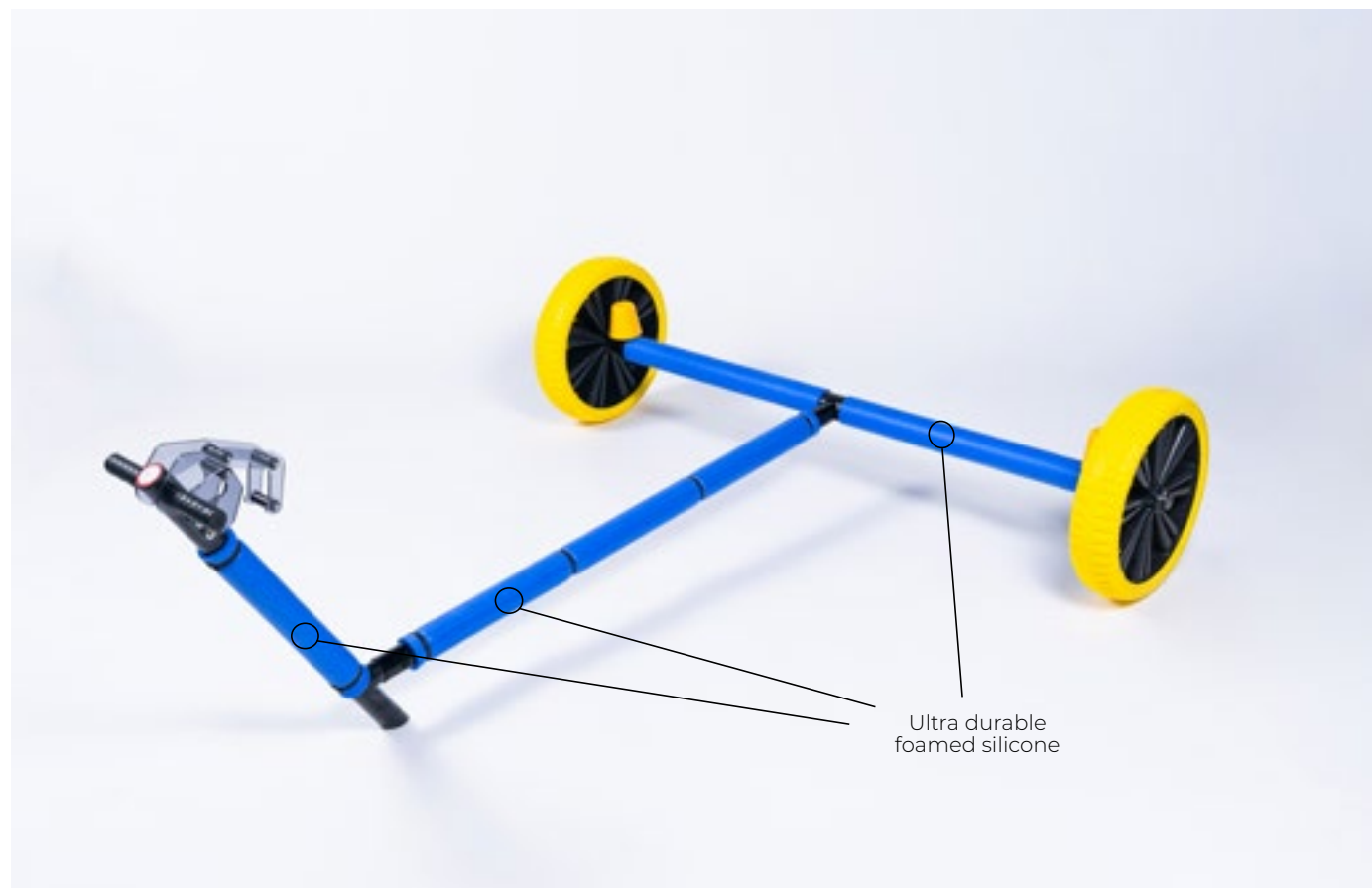

LIMITED EDITION
BLACK COLOUR



W - 310
Trolley Spring locking system



W - 320
Trolley rollers silicone-polyamide OP-5

Trolley Equipment



W - 330
Wheel locking spring for OP-5 Trolley



WN - 321 A/B
Trolley draw bar
A: 1120 mm
B: 1200 mm



W - 350
Wheel Optimast Flex E
Ø 370 mm
Ø 25 mm axle



W - 340
Trolley handle for OP 5 Trolley
Trolley handle Complete Set



W - 381
Bow lock bottom part
8 mm thick



W - 380
Bow lock for OP 5 Trolley
8 mm thick
Set



W - 396
Rotational side support for the trolley
2 pcs. set



W - 390
Rubber handle with aluminium core for OP 5 Trolley

OPTIMAST



Paddles and equipment

Paddle Equipment ■ Paddles

W - 500 A/B
Tiller with extension set releasable joint
Extension colours: WN - 541

W - 510 A/B
Rotational Tiller with extension set releasable joint
Extension colours: WN - 542

WN - 525 A/B
Tiller
A: 570 mm
B: 600 mm

W - 526
Long tiller extension standard grip joint with rope
665 mm long

WN - 541 A/B/C/D
Tiller extension coated with bionano polyolefin joint with rope
615mm

WN - 542 A/B/C/D
Rotational tiller extension coated with bionano polyolefin joint with rope
640mm

W - 570
Tiller extension releasable joint

W - 580
Steering paddle fittings
Set

WN - 571
New joint
Rotational



for ø 16 mm tillers

DSK - 1
DSK atLas steering paddle without fittings

DSK - 2
DSK atLas steering paddle with fittings

DSK - 3
DSK daggerboard FlexiS
37kg

DSK - 4
DSK daggerboard ExeLiXiS
32 - 45kg

DSK - 5
DSK daggerboard DyNaMis
45+kg

WN - 901 A/B/C/D
Daggerboard bungee with blue durable silicone handle
FIXING INCLUDED
2 x 1050 mm
DOES NOT DAMAGE THE DAGGERBOARD

W - 910
Adhesive tephlon glide tape
20 mm x 0,30 mm x 10 m

WN - 902 A/B/C/D
Daggerboard bungee with blue durable silicone handle
FIXING INCLUDED
2 x 1050 mm
DOES NOT DAMAGE THE DAGGERBOARD

A/B/C/D
COLOR OPTIONS FOR EXPANDOR HANDLES

OPTIMAST





Buoys and equipment

TRAINING BUOY INNOVATIVE SYSTEM

triple displacement

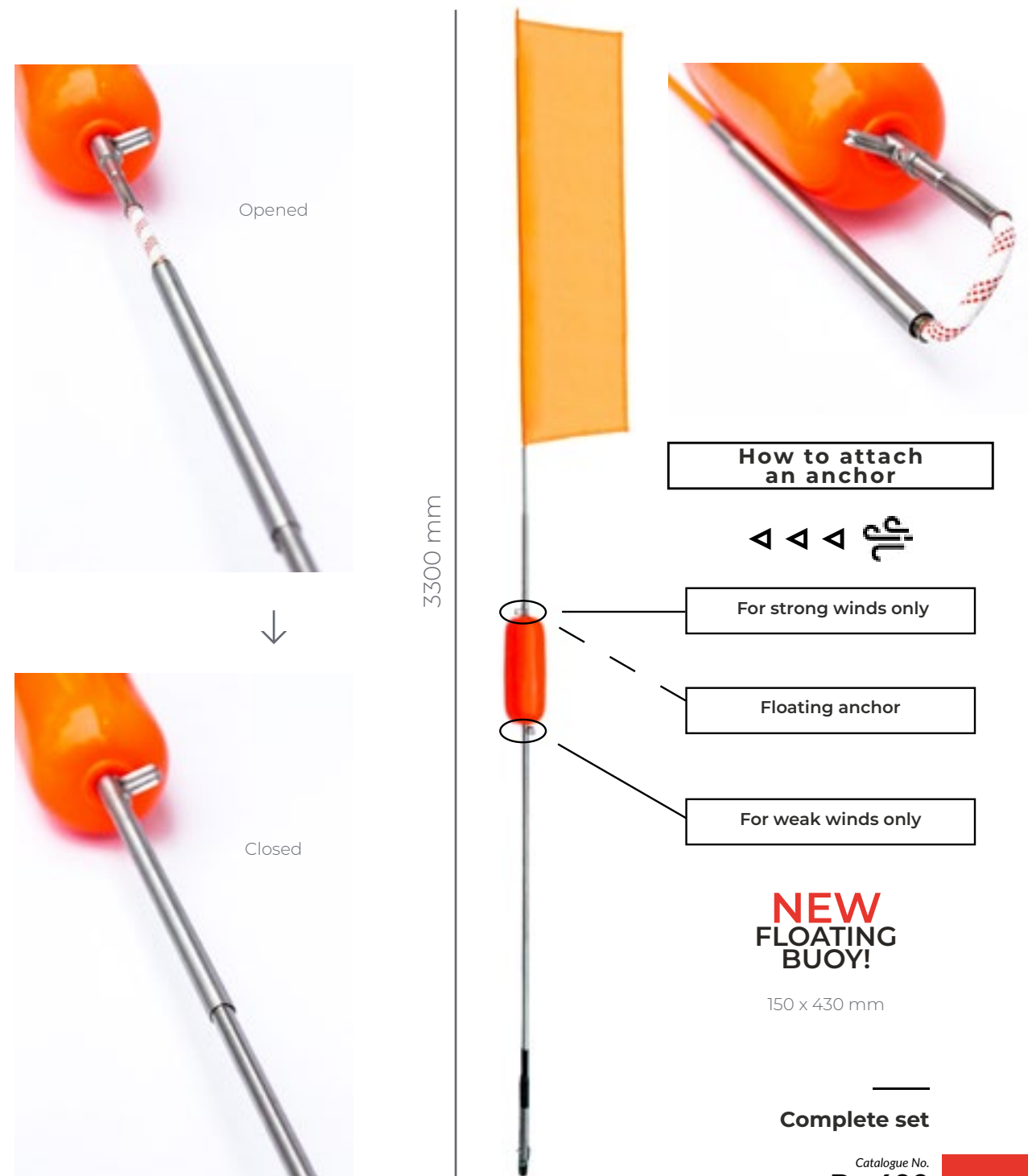

Buoy Equipment Accessories

OPTIMAST

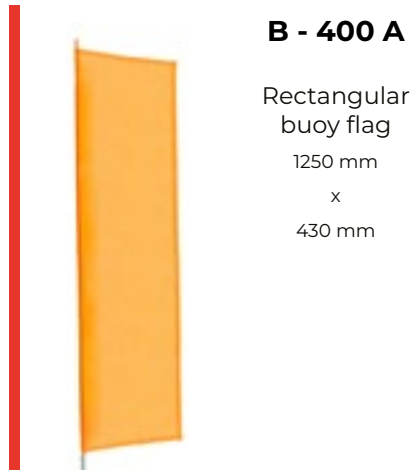

B - 400 A
Rectangular buoy flag
1250 mm
x
430 mm



B - 403
Anchor line
25 m



B - 404
Floating anchor



B - 405
Inflating buoy valve



B - 406
Chain anchor



B - 407
Buoy valve



A - 110 A/B
Optimast whistle
A: Orange
B: Blue



A - 165
Optimast bailer



A - 167
Optimast paddle



NA - 123A
Bailer elastic line with clip
mini clip hook
3 mm



NEW PRODUCT!

A - 169 A
Steel hook with safety screw
Steel 316
Ø 4 mm

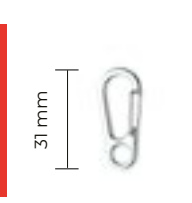

31 mm

NA - 166
Mini clip hook



A - 169
Clip hook
Steel 316



AN - 144
Sailing sponge

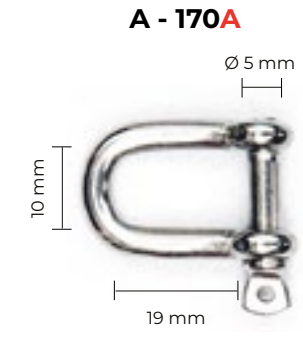

A - 170A

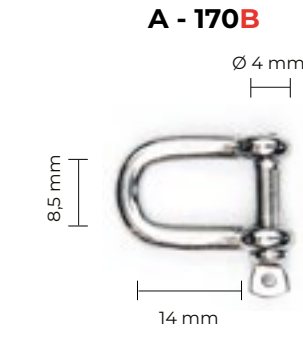

A - 170B

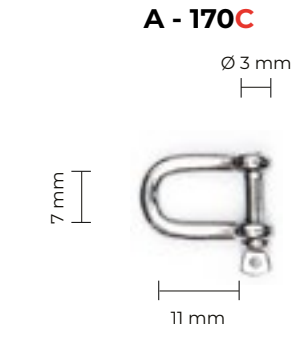

A - 170C



A - 170D

Shackles
A - 316

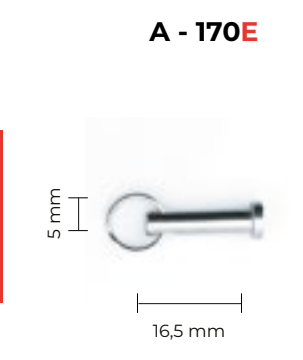

A - 170E



NWZ - 045
Handle for hinch block with fittings



A - 100

Regatta lacing lines



AN - 122N

Boom halyard line Armare
Ø5,6 mm - 530 mm

Packed lines



A - 150

Floating bow line
Stainless steel ring
Pp / Ø 5 mm
8,5 m long



A - 151

Floating bow line
YSM - AREO
Stainless steel ring
Pp / Ø 5 mm
8,35 m long



A - 160

Halyard line
PSE / Kv 1350 mm



A - 161

Super strong
Halyard line
Armare
1350 mm

NEW PRODUCT!



WZ - 005

Outhall
Dyneema line
Tapered
Ø 3 mm < Ø 5 mm



A - 113

International flag
code sticker

OPTIMAST



JOIN THE OPTIMAST CREW AT: [FB.COM/OPTIMAST](https://www.facebook.com/OPTIMAST)

HIKING STRAPS MADE BY RIPPER

—
UPGRADED



A: Blue



B: Pink



C: Red



D: Black

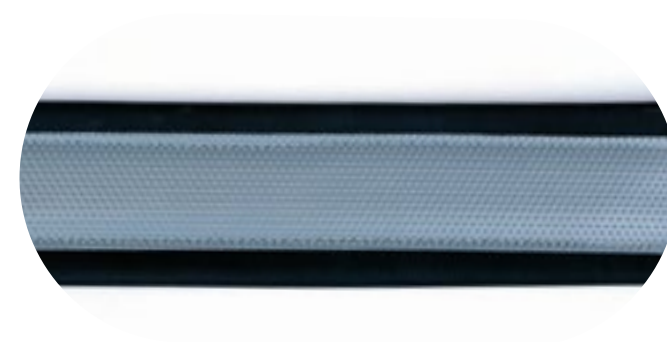

Sticky grip surface

—
New hiking straps
from **RIPPER SAILING**

Catalogue No.
A - 190 A/B/C/D





A - 210
Maffioli regatta
Vectran
Mainsheet
Ø 8 mm / 1 m



A - 214
DynaOne Rope
Gleistein
Ø 3 mm / 1 m



A - 215
DynaOne Rope
Gleistein
Ø 2 mm / 1 m



A - 216
Compact Nero
Rope
Ø 3 mm / 1 m



A - 217
Yellow Fluo
Rope
PES / DYNEEMA
Ø 1,1 mm / 1 m



A - 218
Yellow Fluo
Rope
PES / DYNEEMA
Ø 1,9 mm / 1 m



A - 219
Yellow Fluo
Expandor Elastic
Line PESGF
Ø 5 mm / 1 m



A - 220
Red Expandor
Elastic Line
PESGK
Ø 4 mm / 1 m



A - 221
Red Expandor
Elastic Line
PESGK
Ø 3 mm / 1 m

Ropes and Reels

armare
ropes



MAINSHEET BLOCKS & RINGS

WITH SNAP SHACKLE AND DYNEEMA ROPES



Catalogue No.
WZ - 035 B

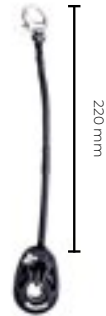

Catalogue No.
WZ - 038 B



Catalogue No.
WZ - 042 B



Single 10x14 friction ring

Catalogue No.
WZ - 035 C

**NEW
PRODUCT!**



Nautos 40 mm
Block + 10x14 friction ring

Catalogue No.
WZ - 038 C

**NEW
PRODUCT!**



Double 10x14
friction rings

Catalogue No.
WZ - 042 C

**NEW
PRODUCT!**



Hoodie Sizes

> XS | XS | S | M | L | XL

Optimast Crew Hoodie

Catalogue No.
WZ - 10000

New
Optimast
T-Shirts



Catalogue No.
WZ - 10001

T-Shirt sizes

> XS | XS | S | M | L | XL

MAST STAND MADE WITH ALUMINIUM

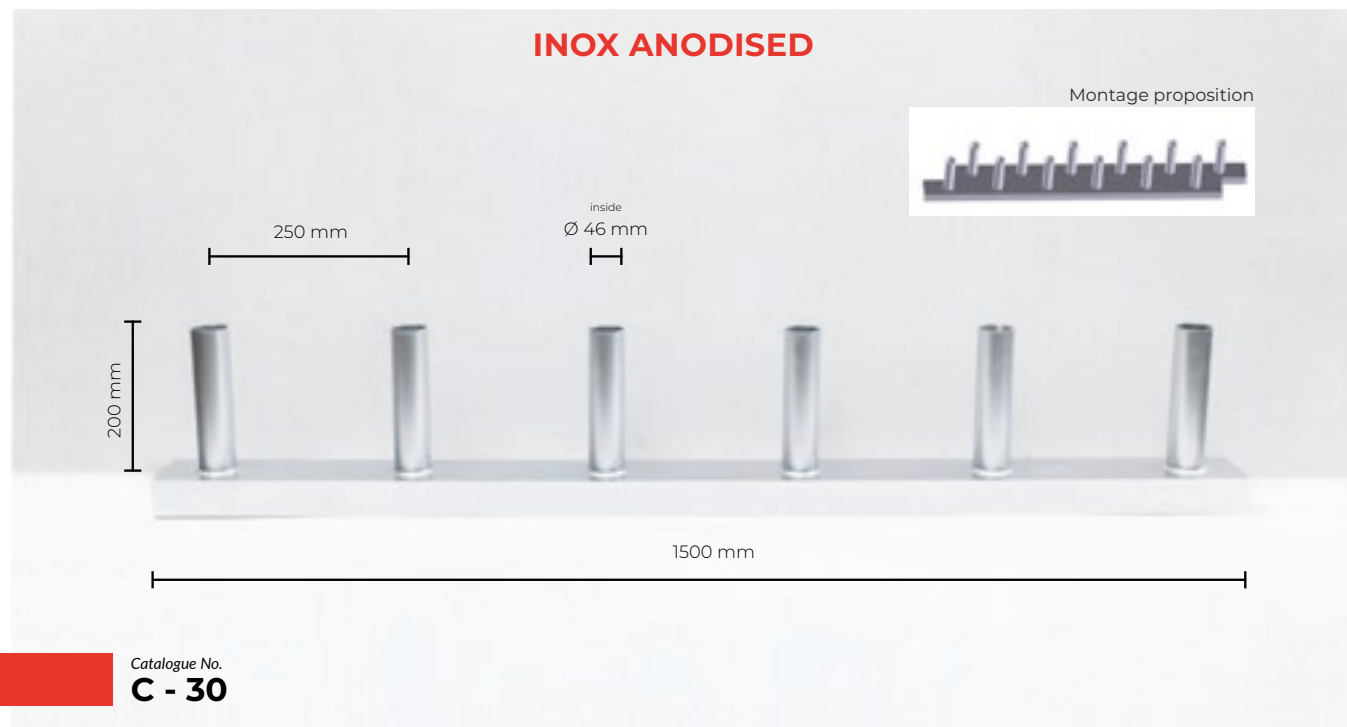

TRANSPORTATION STRAP



OPTIMIST SHELF

TO STORE YOUR OPTIMIST DINGHY

INOX ANODISED

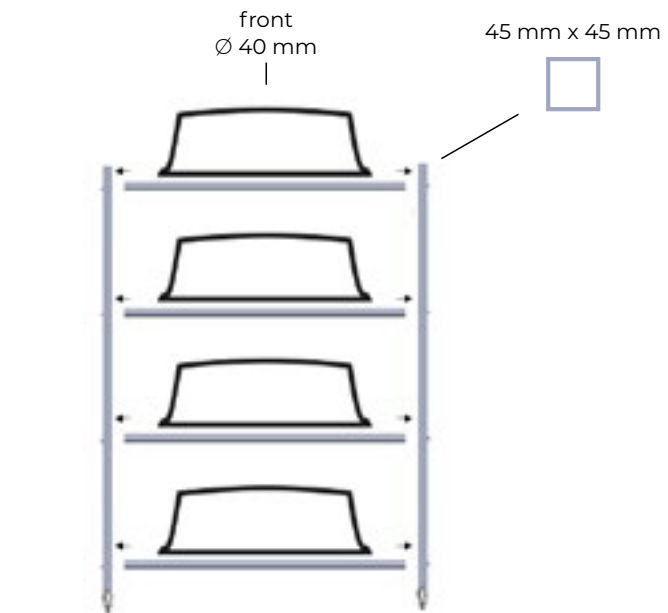

Easy to move with 4 wheels.
Two wheel stops included.

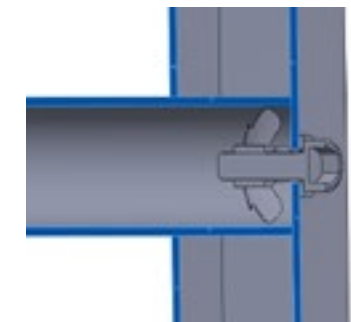
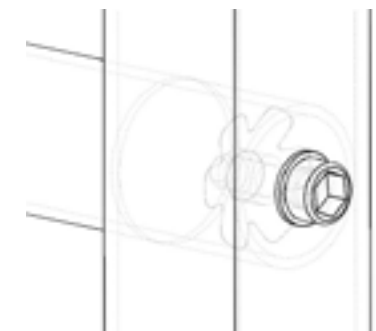

easy to unscrew
for transport

**Weight of 12.5 kg makes
it easy for lifting and moving.**

Catalogue No.
C - 40

OPTIMAST
HOT
DROPS



POLAR WAVE

block with plastic roller + dyneema line 600 mm
Ø 18 mm resistance: 190 kg | breaking load: 500 kg



WZ-N-050 A

WZ-N-050 B

WZ-N-050 D

WZ-N-050 C

POLAR WAVE

block with plastic roller
Ø 18 mm resistance: 190 kg | breaking load: 500 kg



WZ-N-051 A

WZ-N-051 B

WZ-N-051 C

WZ-N-051 D

POLAR WAVE

block with A316 metal roller
Ø 18 mm resistance: 210 kg | breaking load: 640 kg



WZ-N-052 A

WZ-N-052 B

WZ-N-052 C

WZ-N-052 D

POLAR WAVE

block with A316 metal roller
Ø 29 mm resistance: 420 kg | breaking load: 990 kg



WZ-N-054 A

WZ-N-054 B

WZ-N-054 C

WZ-N-054 D





AN - 195

Self-clamping loop

for 3/4 system

- clamping eye for sheet with ball mounted to front cockpit block
- system of changing the ratio of the sheet with a 3/4 ball
- quick release
- 100% Dyneema flat line 2/6 mm



AN - 231

ARMARE

boom halyard rope - tapered with eyelet
Drizza rope

- Diameter:
- Ø 6,80 mm for part 250 mm
 - Ø 5,90 mm for part 700 mm

Length: 940 mm
Resists up to 1080 kg



AN - 232

ARMARE

boom halyard rope - tapered
Lorenz 100% Dyneema 5K78 rope with tapered core

- Diameter:
- Ø 4,20 mm for part 250 mm
 - Ø 4,80 mm for part 700 mm

Length: 1250 mm
Great abrasion resistance



AN - 233

ARMARE

boom halyard rope - tapered with eyelet
100% Dyneema

- Diameter:
- 1st half Ø 4,50 mm
 - 2nd half Ø 2,00 mm

Length: 1190 mm



AN - 234

ARMARE

reinforced mainsheet | tapered | non-symmetrical
Gamberus 2.0 Rope

- Diameter:
- Ø 5,70 mm front part 1800 mm
 - Ø 7,20 mm middle part 3000 mm
 - Ø 5,70 mm back part 3150 mm

Length: 7950 mm



AN - 235

ARMARE

reinforced mainsheet | tapered | non-symmetrical
Gamberus Plus 2.0 Rope

- Diameter:
- Ø 5,70 mm front part 1800 mm
 - Ø 7,20 mm middle part 3000 mm
 - Ø 5,70 mm back part 3150 mm

Length: 7950 mm



AN - 225

ARMARE

Drizza rope | Ø 6 mm | for splicing

- Best use:
- boom halyard
 - outhaul halyard

Resists 1100 kg
Great abrasive resistance



AN - 226

ARMARE

100% Dyneema rope | 1,5 x 3,2 mm | for splicing

- Best use:
- halyards

Resists 960 kg
Great abrasive resistance



AN - 227

ARMARE

100% Dyneema rope | 2.0 x 6,5 mm | for splicing

- Best use:
- halyards
 - clamping eyelets



AN - 228

ARMARE

100% Dyneema rope | Ø 3 mm | for splicing

- Best use:
- halyards
 - outhaul

ARMARE

Optimist stroppi CRD+Pet | Rope for ties | Ø 1,4 mm

Best use:

- ties for sails

Length: 20 m

ARMARE

Optimist stroppi CRD+Pet | Rope for ties | Ø 1,4 mm

Best use:

- corner ties

Length: 20 m

AN - 229



AN - 230



armare
ropes

Faster than
ever before



© Matías Capizzano

© Marek Karbowski

JOIN OPTIMAST CREW



Each client is **unique**. It requires equally special treatment. **Contact us** to receive an individual offer according to your needs and preferences. We are confident that our flexibility will result in long-term cooperation.

Try, see, stay with us for longer.

Quality

The highest quality products ensures its origin. Our equipment is manufactured in 100% in Poland

Experience

Decades of sailing experience of our team knows what it takes to be the fastest

Feedback

We listen to our customers and their comments, trying to reach each individual depending on your preference

Contact us:

optimast@optimast.pl

www.optimast.pl

KEEPER
ONLINE
SAILING

JOIN
THE
OPTIMAST
CREW AT:
[FB.COM/OPTIMAST](https://www.facebook.com/optimast)